



D6.2.1 - Audio Aggregation Platform implementation of “Highway to Europeana - Node on-a-stick”, version 2.

The 'Highway to Europeana' USB card provides a content owner with a simple means of uploading his/her material to the DISMARC/EuropeanaConnect Audio Aggregation Platform (the AAP) for onward distribution to Europeana. Using the system software contained on a USB card, a user can securely prepare, manage and deliver his/her content within the DISMARC environment. Once the system is installed, this work can be carried out either online or offline.



ECP-2008-DILI-528001

EuropeanaConnect

D6.2.1 – Audio Aggregation Platform implementation of “Highway to Europeana - Node on-a-stick”, version 2.

Deliverable number/name	<i>D6.2.1</i>
Dissemination level	<i>PU</i>
Delivery date	<i>October 26 2011</i>
Status	<i>Final</i>
Author(s)	<i>Odo Benda, Gerda Koch, Martin Gordon</i>



eContentplus

This project is funded under the eContentplus programme, a multiannual Community programme to make digital content in Europe more accessible, usable and exploitable.



Österreichische
Nationalbibliothek

EuropeanaConnect is coordinated by the Austrian National Library

Distribution

Version	Date of sending	Name	Role in project
0.1	2011-10-03	Odo Benda, Gerda Koch	AIT, Partner
0.06	2011-10-20	Martin Gordon	WP6
0.11	2011-10-26	Daniel Teruggi, Annelies van Nispen	reviewers

Approval

Version	Date of approval	Name	Role in project
0.11	04.10.2011	Daniel Teruggi	reviewer
0.11	10.10.2011	Annelies van Nispen	reviewer

Revisions

Version	Status	Author	Date	Changes
0.2	Draft	Martin Gordon	2011-10-03	Linguistic edits
0.3 – 0.11	Draft	Martin Gordon	2011-10-28	Intro and operational instructions added following reviewer's comments, screenshots reviewed
1.0	Final	Veronika Prändl-Zika	2011-10-28	Finalisation

Contents:

1) Highway to Europeana	5
Overview	5
Figure 1: The Highway to Europeana USB-card (version 2011).....	5
2) Further Advantages.....	6
3) Architecture of the “Highway to Europeana Node-on-a-Stick”.....	7
Figure 2: Architecture Diagram.....	7
4) Contents of the 2011 USB card Version 2 of the “Highway to Europeana Node-on-a-Stick”	7
5) Operation.....	8
5.1 System requirements.....	8
5.2 Installation.....	8
5.3 Shutting down the system	11

1) Highway to Europeana

Overview

The 'Highway to Europeana' USB card provides a content owner with a simple means of uploading his/her material to the DISMARC/EuropeanaConnect Audio Aggregation Platform (the AAP) for onward distribution to Europeana. Using the system software provided with the USB card, a user can prepare, manage and deliver his/her content within the DISMARC environment. Once the system is installed, this work can be carried out either online or offline.

The Audio Aggregation Platform can be fully or partly deployed on a 'virtual machine' which requires only a player and a low-cost computer system with a connection to the internet. A virtual machine (VM) is a software implementation of a machine (i.e. a computer) that executes programs like a physical machine.

The virtual machine provides a fully-operational system which can be used either as an OAI Data Provider to the Audio Aggregation Platform, or as a separate Audio Aggregation Platform (i.e. as a sub-node).

The USB card contains the DISMARC system software with a VM Player for Windows, operating instructions and additional information about the AAP. (Apple users should use VirtualBox - <https://www.virtualbox.org/>). The USB card contains a full operating system (Ubuntu), a web server (Apache), a database (MySQL) and an XML indexer (IDZebra). The AAP system runs on top of this environment. The AAP system images are based on Ubuntu Server Edition JeOS and generated by VMware Workstation.

In the folder named 'Support and Resources', the user can find guides to DISMARC and to copyright, a Data Assignment agreement (the 'Starter Kit') and various promotional videos.

The card (with 8 gigabytes of software) is available on demand. The card is disseminated via the AAP Newsletter, suitable workshops and via various on-line outlets including the WP6 Moodle.

This concept is referred to as the 'Highway to Europeana'.

Figure 1: The Highway to Europeana USB-card (version 2011)



Users can run the installed system on the USB card or copy it to a local hard drive. Copying the contents of the card onto a local hard drive will significantly improve performance.

The VMware Player should be installed on the user's local computer, following the instructions below. (The VM software is included in the card or can be downloaded from www.vmware.com).

For security reasons the virtual server is configured for a local setup and thus only reachable from the computer which it is running on. If a user wants to make the server accessible via the internet, the network type of the VMware Workstation should be changed from **NAT** to **bridged** and the network in the virtual server should be configured with the IP address given by the user's network provider.

After setting up a local EuropeanaConnect/DISMARC node, the registered user can periodically run an automated data upload routine, from the local cataloguing system to the local Metadata Manager (via time-based scheduling services such as Cron on *nix and Schedule Tasks on Windows).

If users require local data to be regularly harvested by the AAP, they can allow web access to the local server hosting their metadata. The central AAP Harvester will then periodically check for new data in the local system and will harvest these updates to the AAP.

2) Further Advantages

Running a local Metadata Manager additionally provides the possibility of connecting to any OAI repository worldwide for situations where the partner wishes to distribute metadata to portals other than EuropeanaConnect/DISMARC. The local Metadata Manager can also be used to collect metadata information from other local sub-repositories before providing them in one delivery to the Audio Aggregation platform. This functionality supports the creation of Europe-wide national repositories for the aggregation of data and for the subsequent provision of this data to the Audio Aggregation Platform.

3) Architecture of the “Highway to Europeana Node-on-a-Stick”

Figure 2: Architecture Diagram

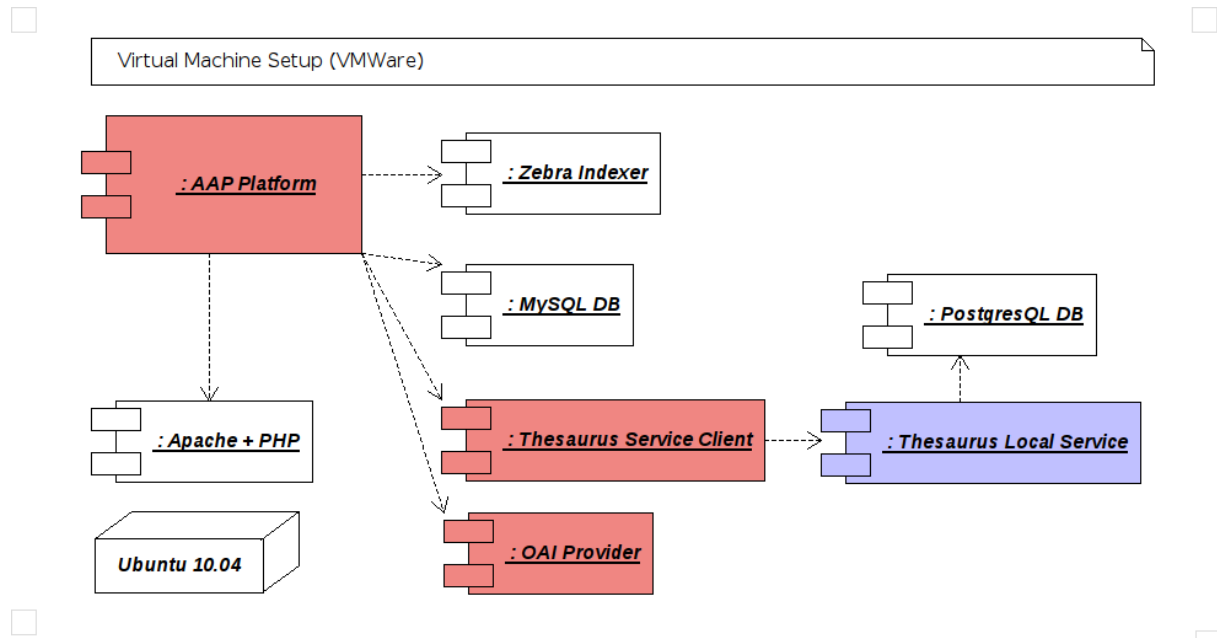

The 'Highway to Europeana' card is a virtual server that hosts the complete environment for the Audio Aggregation Platform. The virtualisation system used is VMware. It contains a full operating system (Ubuntu) a web server (Apache) a database (MySQL) and an XML indexer (IDZebra). The AAP setup runs on top of this environment. The 'Highway to Europeana' is configured with the AAP layout including a web service client for the thesauri used by DISMARC and an OAI provider.

4) Contents of the 2011 USB card Version 2 of the “Highway to Europeana Node-on-a-Stick”

Highway to Europeana – Overview

- An overview and technical specification of the 'Highway to Europeana' Virtual Server

Highway to Europeana – Installation

- Instructions for installing the 'Highway to Europeana' virtual server.

Folder '20111003'

- § This folder contains the current (**September 2011**) **Version** of the DISMARC/EuropeanaConnect Audio Aggregation Platform. All **vocabularies** connected to the card via web services have now also been uploaded to the card.
- § In order to support small audio archives the **AAP Metadata Entry** sheet is also available on the stick. It is accompanied by a short **guideline** to the usage of

substitution lists and a **sample substitution** list for alignment of local vocabularies with vocabularies used within the audio aggregation platform.

Folder ‘Support and Resources’

This folder contains:

- Guide to Copyright for Archives
- Guide to the DISMARC Audio Aggregation Platform
- DISMARC FAQs/Data Assignment
- (in the subfolder ‘Video’) promotional videos featuring the “Weddings in Eastern Europe” audio exhibition, the “Audio Aggregation Platform and an overview of the technical aspects of DISMARC.

5) Operation

5.1 System requirements

To run the card a user needs:

- VMware Player 4 (included with the USB card) or VMware Workstation 6+. (Apple users should use VirtualBox - <https://www.virtualbox.org/>).
- 768MB unused RAM (= free memory after your host system has started)
- a LAN network with automatically-assigned IP addresses. The virtual server will automatically acquire an IP address from the user’s local network via DHCP.

5.2 Installation

1. Insert the USB card into an available USB slot on your computer.
2. In the folder ‘20111003’, click on the VMware Player icon, and follow the installation instructions shown. If there is an existing VM Player on your computer, it will be updated.

This operation will create a Virtual Machine which can be connected to either the internet or to your intranet, and it will also create a network between your computer and the Virtual Machine for offline use.

3. Restart your computer as prompted.
4. After a successful installation, you will see the VM Player icon. Open the VM Player and accept the license as requested.
5. A VM Player window pops up.



6. Select 'Open a Virtual Machine'.
7. A selection box will open. Navigate to the USB 'Highway to Europeana' card.

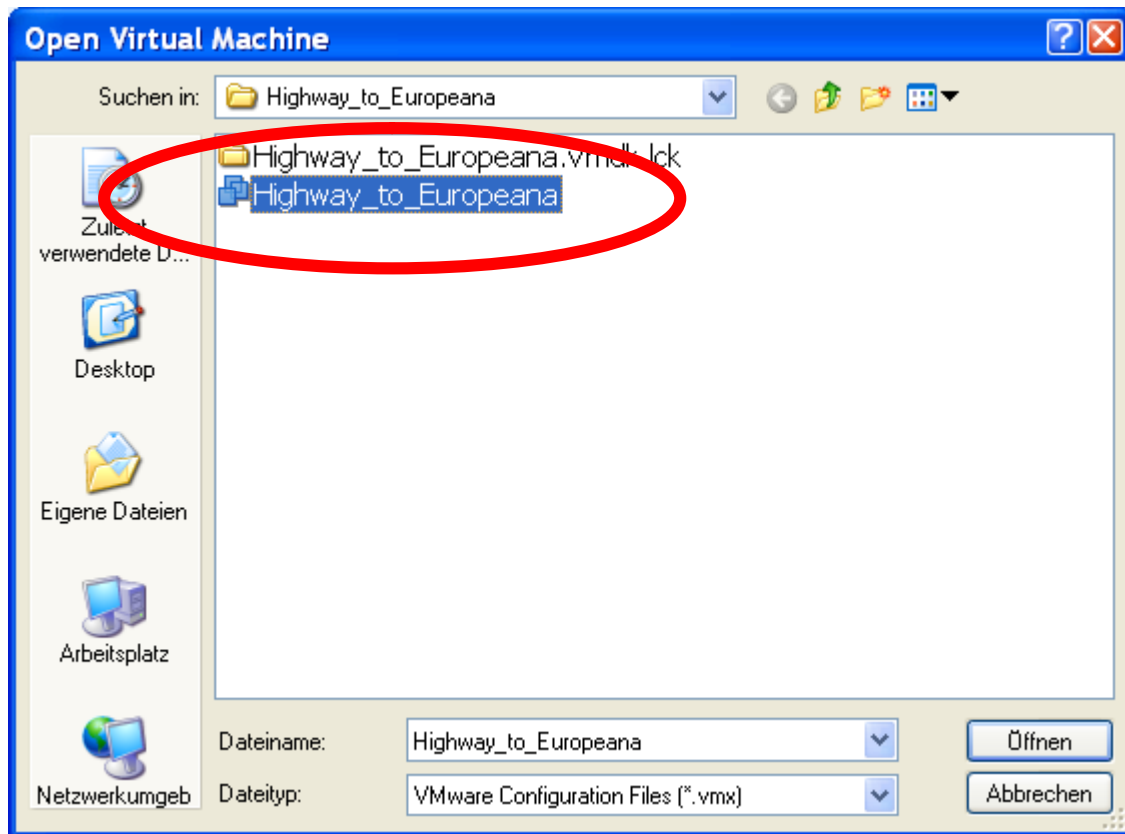

8. In the folder '20111003'/subfolder 'Highway_to_Europeana', click on the 'Highway_to_Europeana' file to begin the DISMARC system. (This file is a VMware Configuration File).
9. If you are asked whether you moved or copied the virtual machine, select 'copied', by clicking 'I copied it'. If you are asked to download or install VMWare Tools for Linux, click on 'Remind Me Later' – VMWare Tools for Linux is not needed to run the DISMARC system.
10. The system starts.

The system version on the USB card is the Linux/Ubuntu desktop version. Your computer will give you hints on how to switch between the virtual server and your local computer.

11. When finished booting, the system will display the IP address of the DISMARC system on the virtual network.
12. You can now access the system in your preferred browser using this address. Open your browser and enter the IP address into the browser address bar.
13. Your browser connects to the DISMARC system on your stick.
You can now log into the DISMARC system with the user name **admin** and the password **highway**. To log-in as administrator of the virtual server, log in with user name **highway** and the password **highway**. For security, you should change these passwords once logged in.

14. Manage your data as you would normally do via the online DISMARC Audio Aggregation Platform. For operating instructions to DISMARC, please read the document ‘EuropeanaConnect DISMARC Guide to Audio Aggregation Platform’ on the USB card, in the folder ‘Support and Resources’. This Guide is also online at http://www.dismarc.org/info/pdf/Guide_to_AAP.pdf.

5.3 Shutting down the system

1. Go to the Virtual Machine player, which you will find in the already-open ‘Highway to Europeana’ tab.
2. Click in the black space and log in to the system using the username **dismarc** and the password **dismarc**.
3. Type in the instruction **sudo halt** and press the enter key.
4. When requested, respond with the password **dismarc**.
5. The system shuts down.

The WP6 technical team provides a help line for institutions which want to use the ‘Highway to Europeana’ virtual server. Please contact us via dismarc.admin@ciscaustria.at for further support!